

FSN / FSNX

FOR HEAVY DUTY FLOORS

MIGUTRANS

HEAVY-DUTY ALL-METAL JOINT SOLUTIONS
FOR LARGE TRAFFIC LOADS

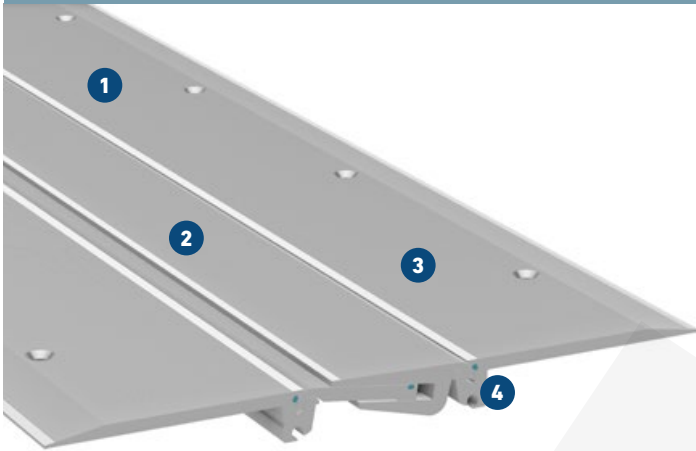

- 1 Solid all-metal expansion joint**
hard wearing, maintenance-free, long lasting
- 2 Visible surface has no gaps**
avoids dirt accumulation
- 3 Striated surface**
ensures good skid resistance
- 4 Articulated telescoping system**
absorbs movement in 3 directions

Expansion joint cover	Joint width min. b_f [mm]	Total movement Δb_f [mm]	Visible width b_s [mm]	Joint width total b_t [mm]	Installation height h [mm]	Thickness of alu side plates h_1 [mm]	Load bearing capacity [kN]	Load bearing capacity [kN]	Load bearing capacity [kN]	Load bearing capacity solid plastic tyres [kg/mm]
FSN 46 */**	50	20 (± 10)	286	286	21	6,6	90	70	70	6,5
FSNX 75	84	20 (± 10)	320	320	21	6,6	90	70	70	6,5
FSN 105	112	20 (± 10)	348	348	25	6,6	90	70	70	6,5
FSN 110	118	30 (± 15)	354	354	21	6,6	90	70	70	6,5
FSN 130	142	40 (± 20)	378	378	28	6,6	90	35	35	6,5
FSN 155 **	162	40 (± 20)	398	398	24	6,6	90	35	35	6,5
FSN 160	170	60 (± 30)	406	406	34	6,6	90	35	35	6,5
FSN 185 **	200	60 (± 30)	409	409	18	6,6	90	35	35	6,5
FSN 280 **	240	85 ($\pm 42,5$)	454	454	21	6,6	35	35	35	6,5
FSN 285 **	290	100 (± 50)	508	508	28	6,6	35	35	35	6,5

* cannot take settlements

** The joint width should not differ substantially from the necessary joint width b_f .

Production length: 4 m (FSN 185, FSN 280 and FSN 285: 3 m)

Standard colour: Aluminium

Corner versions:

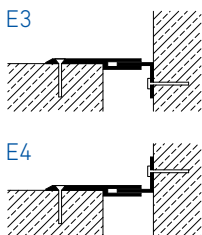

FSNX 110

